



DH-F5



●FEATURES:

1. High current operation.
2. High flux output.
3. Low thermal resistance.
4. Low profiler.

●APPLICATIONS:

1. TV set.
2. Monitor.
3. Telephone.
4. Computer.
5. Circuit board.

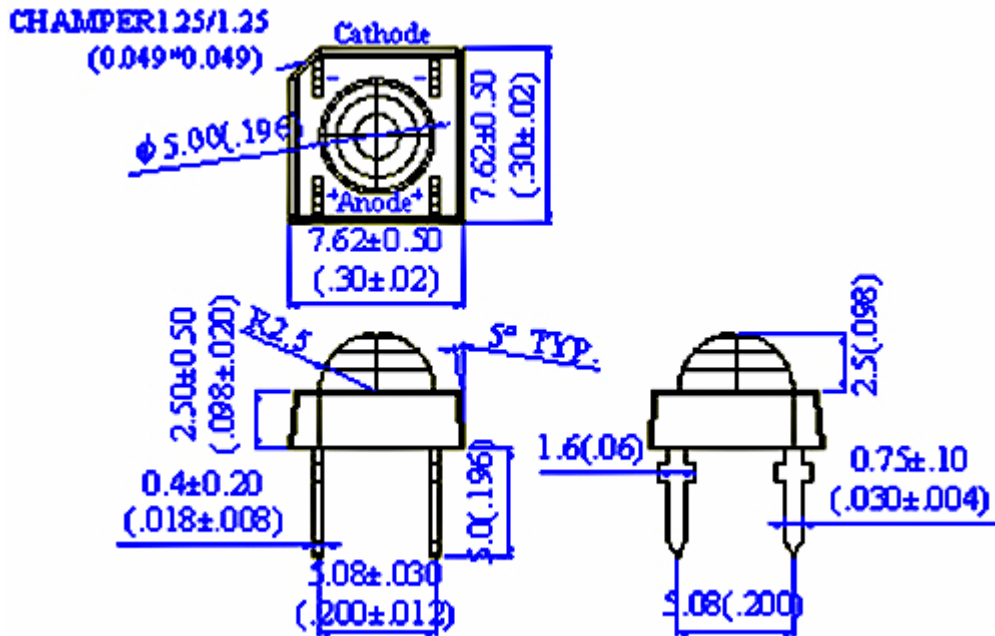

Part No.	Chip			Lens Color	Vf (v)		Iv (mcd) IF=20 mA		Viewing Angle 2θ1/2
	Material	Emitted color	λp (nm)		Typ	Max	Min	Typ	
DH-F5URC	AlGaInP	Red	630	Water Clear	1.7	2.6	/	3500	60
DH-F5UYC	AlGaInP	Yellow	590	Water Clear	2.0	2.6	/	3500	60
DH-F5DBC	InGaN	Bluish Green	505	Water Clear	3.1	3.8	/	5000	60
DH-F5PGC	InGaN	Pure Green	515	Water Clear	2.8	3.6	/	5000	60
DH-F5SBC	InGaN	Blue	470	Water Clear	2.8	3.6	/	3000	60
DH-F5SWC	InGaN	White	X=0.31 Y=0.32	Water Clear	2.8	3.6	/	5000	60
DH-F5RGB	AlGaInP	Red	625	Water Clear	1.7	2.6	/	1200	80
	InGaN	Pure Green	515		2.8	3.6	/	1900	
	InGaN	Blue	470		2.8	3.6	/	1200	